

> **External Debeading Tool**
to $\geq 400\text{mm}$

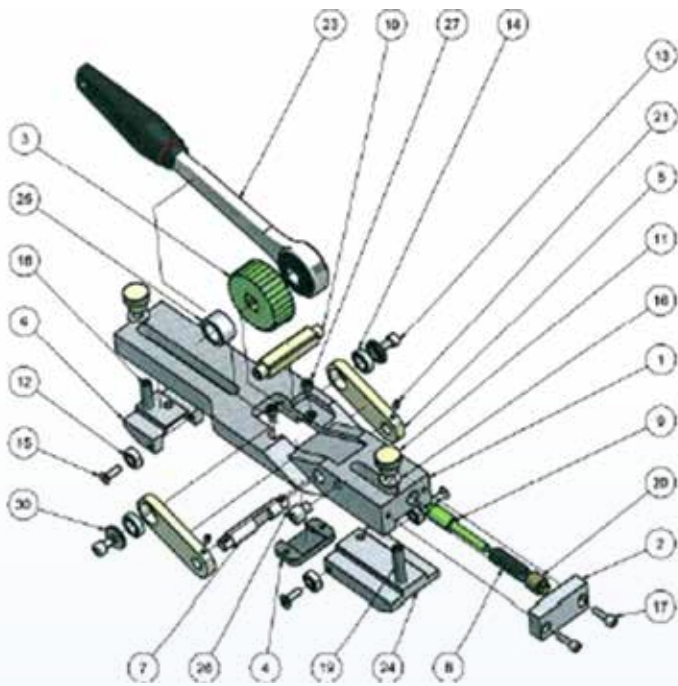

Specifications / $\geq 400\text{mm}$

Complete Unit: Code	P9.630.400
Materials	Mild Steel EN1A / Mild Steel EN16T / Mild Steel EN3B / Aluminium / Nylon
Finish	Yellow and Silver zinc plated (Steel)
Dimensions	385mm x 750mm x 85mm
Weight 125mm	2.5 KG
Replacement Blade: Code	P9.634.400



Parts List / 400mm

Item	Product Code	Description	Qty
1	Z01-07-515	400mm Debeader Body	1
2	Z01-07-516	Aluminium Ware Block	1
3	Z01-07-517	Bead Ratchet Wheel	1
4	P9.634.400	Debeader Blade 400mm	1
5	Z01-07-522	Side Link	2
6	01-07-509	Adjustment Block Small	1
7	Z01-07-529	Spring Loaded Spindle 400mm	1
8	Z01-07-518	Spring Debeader	1
9	Z01-07-519	Spring Loaded Actuator Pin	1
10	Z01-07-530	Square Ratchet Shaft 400mm	1
11	Z01-07-520	Thumb Screw	2
12	Z256-A011-014	Bearing (Adjustment Block)	4
13	Z183-T006-153	M6 x 12 Cap Head Socket Screw	2
14	Z256-A011-003	Bearing (Side Link)	2
15	Z183-T006-140	M5 x 12 Csk Socket Screw	4
16	Z183-T006-180	M8 Washer 20 OD	2
17	Z183-T006-131	M5 x 16 Cap Head Socket Screw	2
18	Z183-T006-194	M8 x 30 Socket Set Screw	1
19	Z183-T006-210	M8 x 40 Socket Set Screw	1
20	Z01-07-521	Spindle Plunger Pressure Screw	1
21	Z183-T006-019	M4 x 8 Socket Set Screw	2
23	Z01-07-531	Single Ratchet	1
24	Z01-07-532	Adjustment Block Long 400mm	1
25	Z01-07-533	Ratchet Spacer 400mm	1
26	Z183-T006-208	M8 x 8 Cap Head Socket Screw	1
27	Z183-T006-141	M5 x 8 Cap Head Socket Screw	2
30	Z01-07-534	Side Link Bearing Spacer Washer	2

Basic Working Instructions

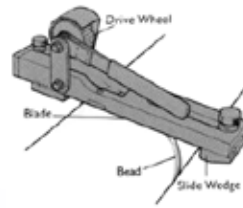

1.
Move both wedges to their outer limits, raise the drive wheel and place the tool on the bead.

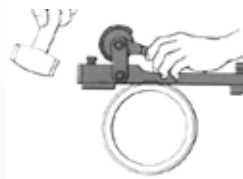

2.
Drive the knife blade into the bead to give approximately 25mm of free bead.

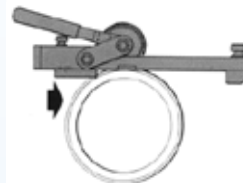

3.
Drop the drive wheel down to grip the bead. Move the rear wedge into position and lock at the mark corresponding to the pipe size.

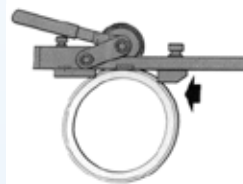

4.
Move front wedge until it is just touching the pipe.



5.
Apply pressure to the ratchet handle and move the tool around the pipe.

This unit is design and manufactured to meet the requirements of GIS/PL2-5:2006 Part 5:

This product has no calibration period. Periodic, safety inspection should be carried out by the operator. If in doubt, please contact the manufacturer for further information.

HONG KONG

info@mill-pro.com.hk
phone +852 254 36200
office: Room 503, Tai Tung Building, 8 Fleming Road, Wanchai

NEW ZEALAND

info@mill-pro.co.nz
phone +64 6 836 7919
post: PO Box 7014 Taradale, Napier 4141